

ELEVATION

FRONT VIEW

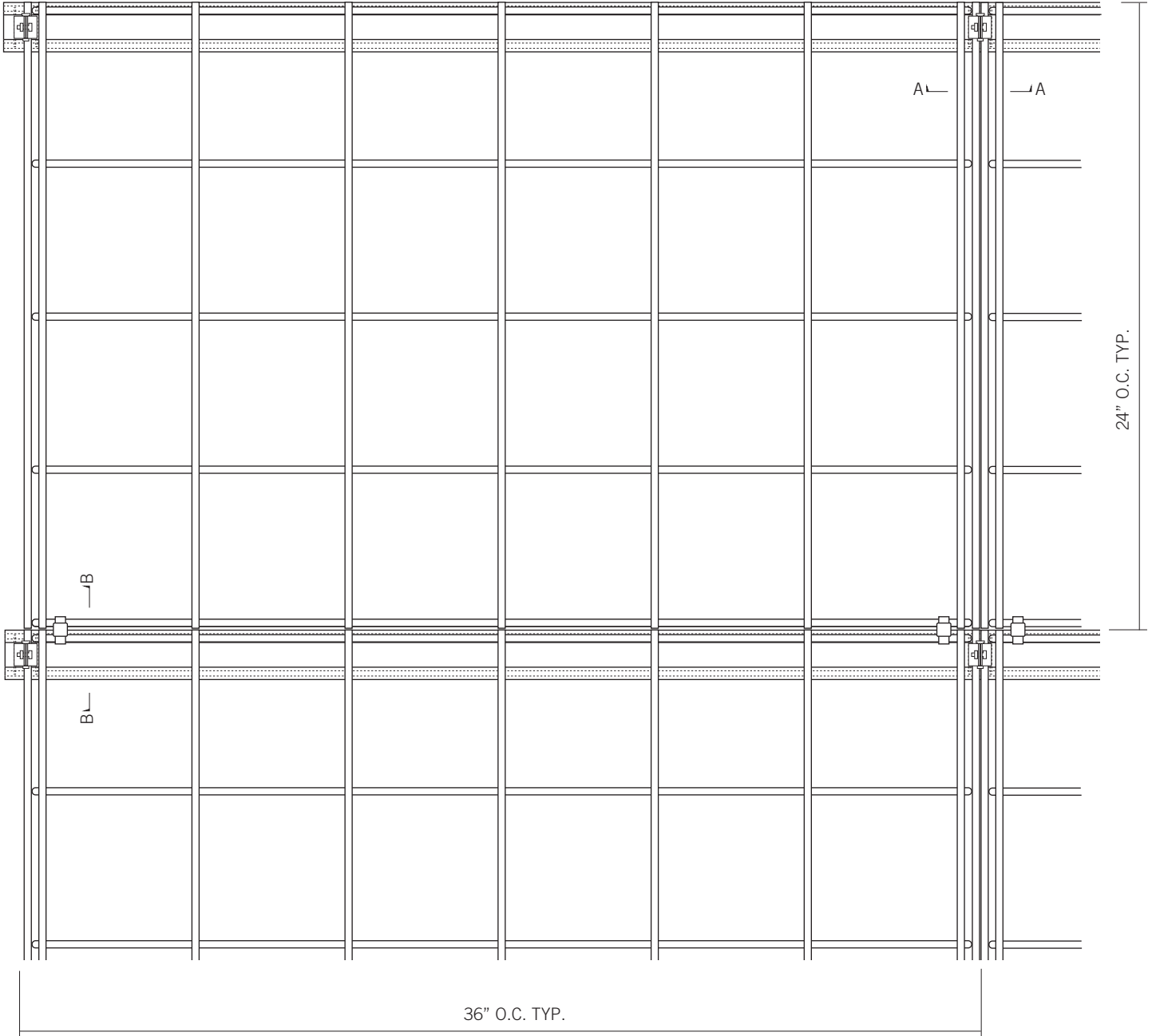

DESIGNS ARE FOR SUGGESTED USE ONLY  
LOCAL BUILDING CODES MAY APPLY

V.05/02/2017

LIABILITY STATEMENT: Florafelt and/or Plants On Walls is not responsible or liable for care and maintenance of plants used in our Florafelt living wall panels, Floraframe living wall systems, Root Wrappers or any other products or services. Florafelt and/or Plants On Walls is not responsible or liable for water damage to interior or exterior of buildings, homes, or finishes due to misuse or accidental moisture dripping from plants, lack of maintenance of watering systems, or for any reason for moisture damage or loss due to damages of any kind. It is up to the purchaser to properly protect all surfaces from water exposure or overflow by providing water catchment drain trays and/or vapor barriers to areas of potential damage. It is the responsibility of the property owner to get all applicable permits and comply with local building codes. We recommend the hiring of qualified landscape maintenance professionals to assist with plant selection, planting, watering, feeding, pest control, lighting, and general maintenance to assure optimal health for the living wall. Plants On Walls / Florafelt is not responsible and to be held harmless to damage to buildings, water leakage, loss of plants, bodily harm, or any accidental damages of any kind. ©2015 Plants On Walls / Florafelt Corporation. U.S. and International Patents. Made in USA.

# WIRE GRID MOUNTING DETAIL FULL SIZE CHANNEL

## SECTION DETAIL A-A

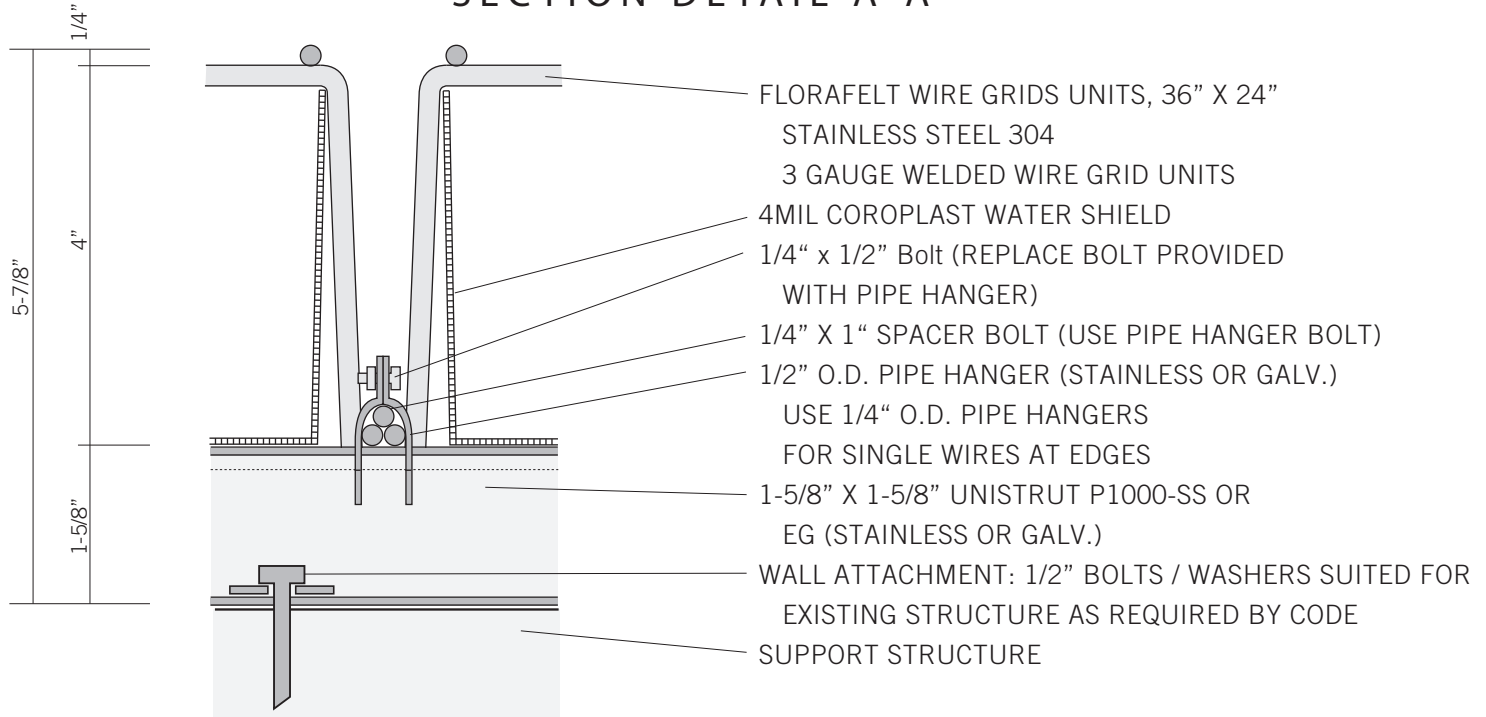

## SECTION DETAIL B-B

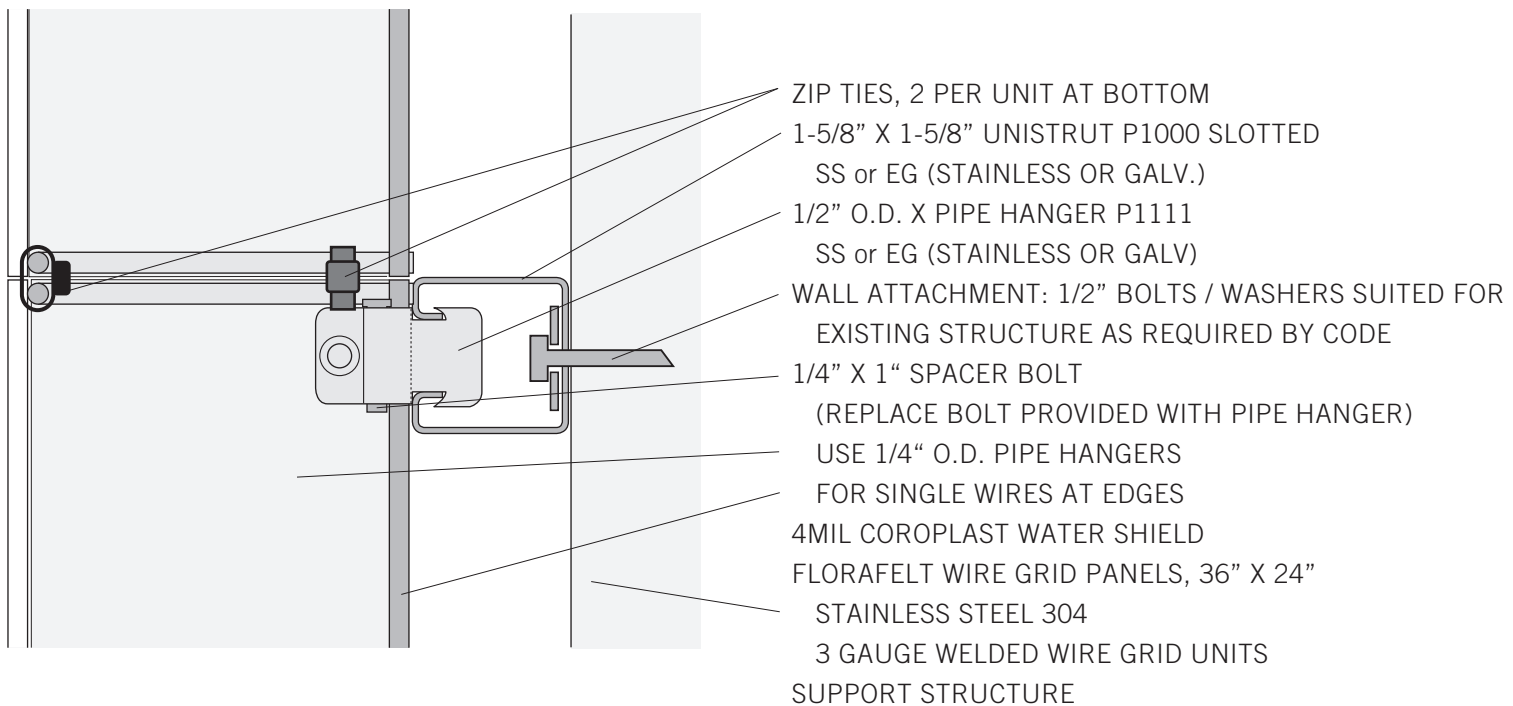

DESIGNS ARE FOR SUGGESTED USE ONLY  
LOCAL BUILDING CODES MAY APPLY

V.05/02/2017

LIABILITY STATEMENT: Florafelt and/or Plants On Walls is not responsible or liable for care and maintenance of plants used in our Florafelt living wall panels, Florafelt living wall systems, Root Wrappers or any other products or services. Florafelt and/or Plants On Walls is not responsible or liable for water damage to interior or exterior of buildings, homes, or finishes due to misuse or accidental moisture dripping from plants, lack of maintenance of watering systems, or for any reason for moisture damage or loss due to damages of any kind. It is up to the purchaser to properly protect all surfaces from water exposure or overflow by providing water catchment drain trays and/or vapor barriers to areas of potential damage. It is the responsibility of the property owner to get all applicable permits and comply with local building codes. We recommend the hiring of qualified landscape maintenance professionals to assist with plant selection, planting, watering, feeding, pest control, lighting, and general maintenance to assure optimal health for the living wall. Plants On Walls / Florafelt is not responsible and to be held harmless to damage to buildings, water leakage, loss of plants, bodily harm, or any accidental damages of any kind. ©2015 Plants On Walls / Florafelt Corporation. U.S. and International Patents. Made in USA.

# WIRE GRID MOUNTING DETAIL SUPPORTED NARROW CHANNEL

## SECTION DETAIL A-A

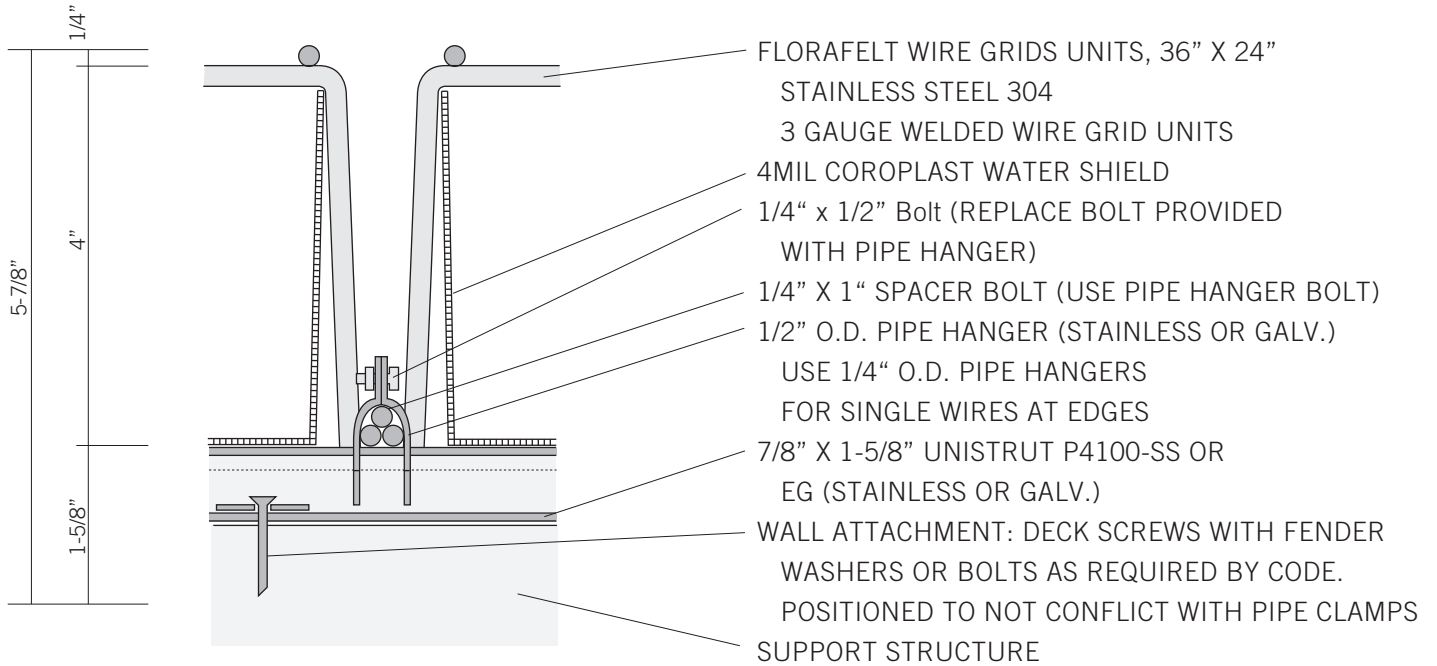

## SECTION DETAIL B-B

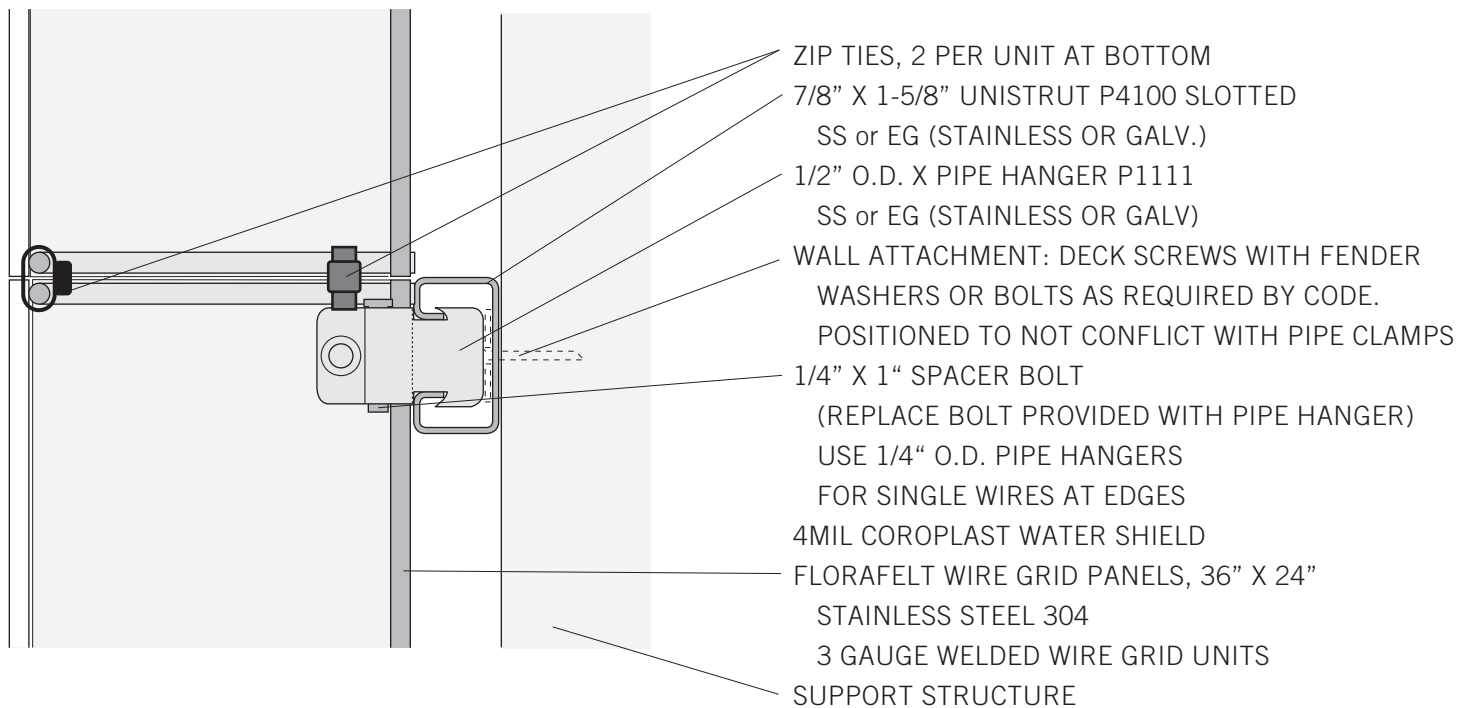

DESIGNS ARE FOR SUGGESTED USE ONLY  
LOCAL BUILDING CODES MAY APPLY

V.05/02/2017

LIABILITY STATEMENT: Florafelt and/or Plants On Walls is not responsible or liable for care and maintenance of plants used in our Florafelt living wall panels, Florafelt living wall systems, Root Wrappers or any other products or services. Florafelt and/or Plants On Walls is not responsible or liable for water damage to interior or exterior of buildings, homes, or finishes due to misuse or accidental moisture dripping from plants, lack of maintenance of watering systems, or for any reason for moisture damage or loss due to damages of any kind. It is up to the purchaser to properly protect all surfaces from water exposure or overflow by providing water catchment drain trays and/or vapor barriers to areas of potential damage. It is the responsibility of the property owner to get all applicable permits and comply with local building codes. We recommend the hiring of qualified landscape maintenance professionals to assist with plant selection, planting, watering, feeding, pest control, lighting, and general maintenance to assure optimal health for the living wall. Plants On Walls / Florafelt is not responsible and to be held harmless to damage to buildings, water leakage, loss of plants, bodily harm, or any accidental damages of any kind. ©2015 Plants On Walls / Florafelt Corporation. U.S. and International Patents. Made in USA.

## WEIGHTS TYPICAL

FLORAFELT / WIRE GRID / UNISTRUT WEIGHTS ESTIMATED CALCULATIONS

3' X 2' 6X6X1/4 SS FOLDED S.S. WIRE GRID WITH FELT AND WATER BARRIER. 12.4 LBS  
-  $12.4 / 6 \text{ SF} = 2.1 \text{ LBS / SF}$

WRAPPED PLANTS 6" POTTED IN 16" FLORAFELT ROOT WRAPPER SOME SOIL REMOVED:  
1-2 LBS EACH (4 PER /SF)  
- 4 - 8 LBS/SF

HORIZONTAL 1-5/8" X 1-5/8" UNISTRUT SS 24" O.C. 10' PIECE = 17.6 LBS  
- 3' SECTION PER 3'X2' PANEL = 5.28 LBS  
-  $5.28 \text{ LBS} / 6 \text{ SF} = .88 \text{ LBS /SF}$

HARDWARE SS 304  
- VARIES BY PROJECT